

Rosenbauer High Performance ARFF Vehicles

CTIF Meeting Linz

DI Herbert Poellinger

June 15, 2011



High Performance ARFF Vehicles



■ The history

■ Demand and supply

- 1980's – Fraport demands high horsepower to weight ratio to meet ICAO response with minimum number of fire stations and minimum number of vehicles
- Conventional RIV and major tender concept under pressure
- Demand for RIV performance at major size
- 1250 HP SIMBA 8x8 development with FRA
- 0 to 80 kph in less that 25 sec at 44 tons
- Massive drive engine (MTU 31,7 liter)
- Additional pump engine
- Limited market (FRA, MUC)
- Benchmark for years to come!



High Performance ARFF Vehicles



■ Learning from history

- Creating a market
- Market drives development – product only for the driver of development
- Drive the market with the right product and the market will respond
 - 1991 Introduction - Panther 8x8
 - High performance, one can see!
 - Design and performance = Success



High Performance ARFF Vehicles



- **Getting caught by history**
 - Improve the good and become better
 - All components need to improve to meet the newer standards
 - What if, one doesn't and it is not yours?
 - You need to do it by yourself!



High Performance ARFF Vehicles



- **Re-inventing history**
 - Performance is the highest goal
 - New standards to be met
 - Fresh ideas needed
 - Be the Apple!

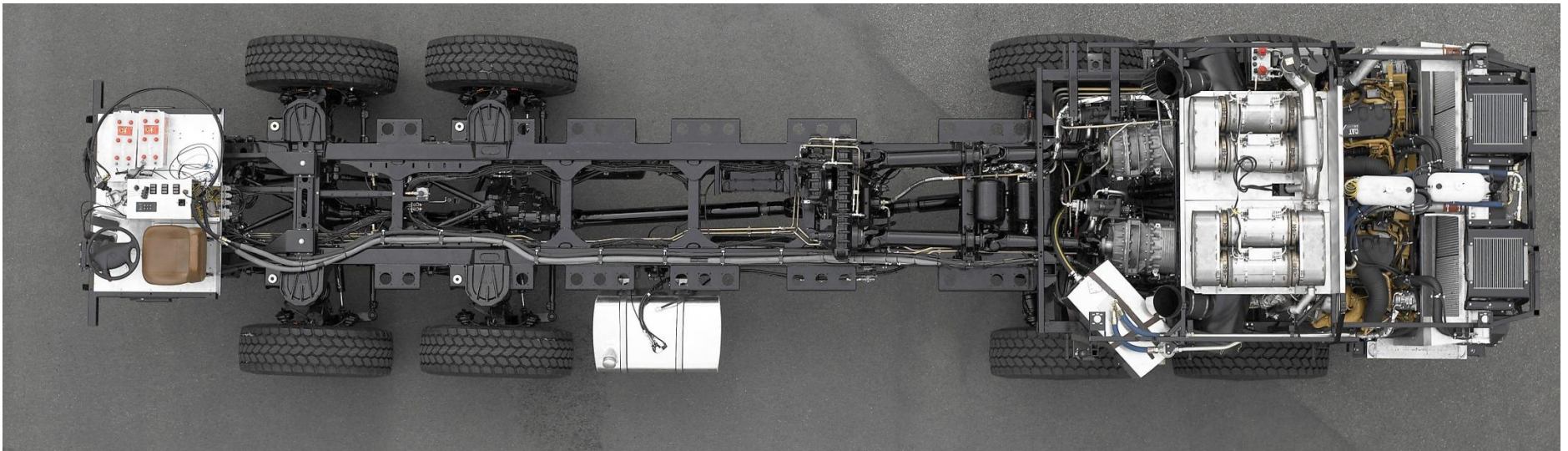

High Performance ARFF Vehicles



■ Making history (again)

- 0 to 80 in less than 22 sec at 45 tons (25 sec at 52 tons)
- Top speed of > 135 kph
- Meet all emission standards
- Setting the benchmark again for years to come!



High Performance ARFF Vehicles

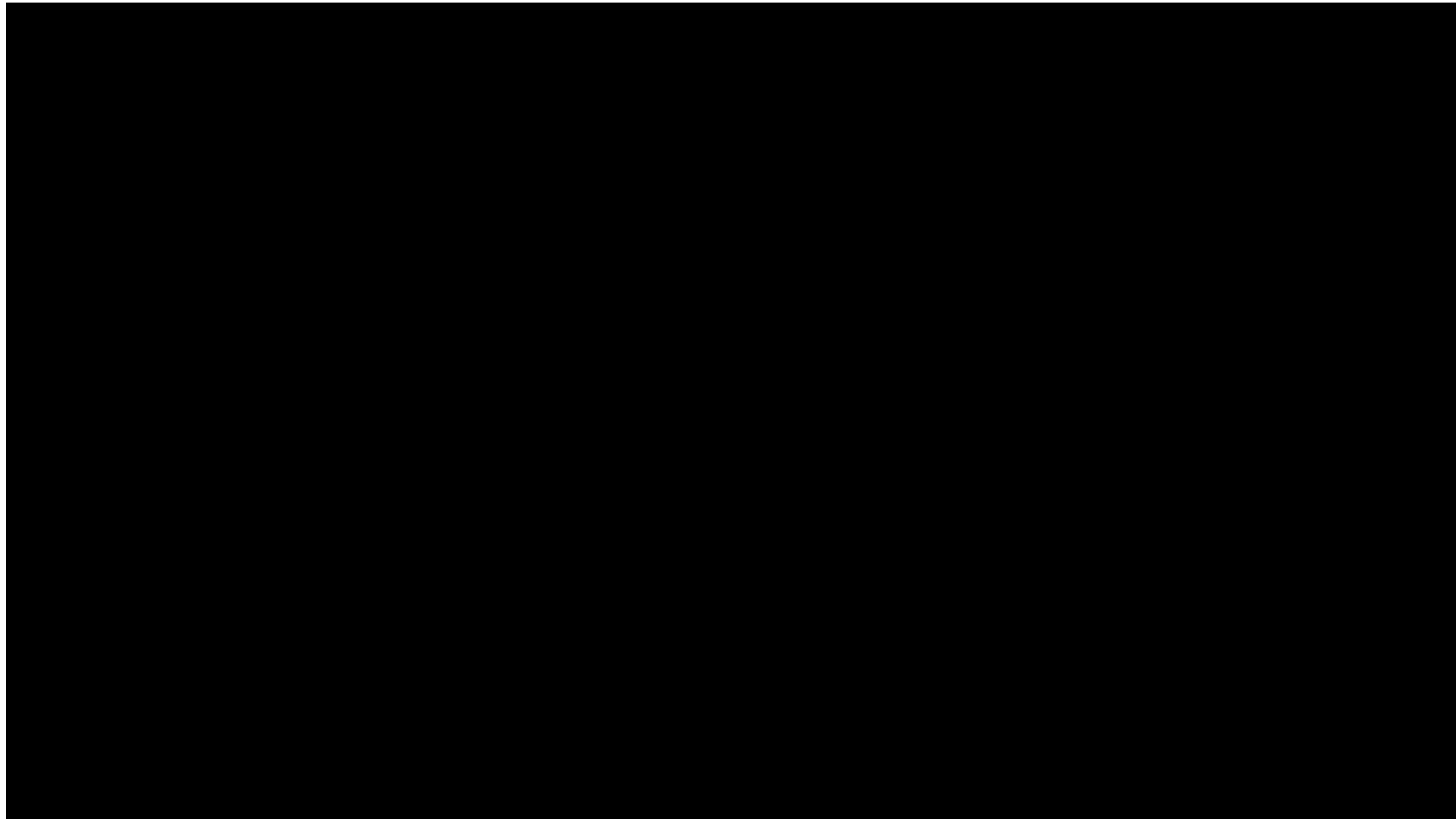

Rosenbauer product news



■ Pilot Rescue System



■ Pilot Rescue System



■ Pilot Rescue System



Rosenbauer product news



■ Pilot Rescue System



■ Escape Stair E- 8000



Rosenbauer product news



■ Escape Stair E- 8000



■ Escape Stair E- 8000



■ Escape Stair E- 8000



Thank you!

Rosenbauer International AG
4060 Leonding, Paschinger Str. 90, Austria
Tel: +43 732 6794-446, Fax: +43 732 6794-94 446
sfv-7@rosenbauer.com
www.rosenbauer.com

